

October 2011

Volume 12, Issue 4

ANODE

Inside this issue:

Editor's Comments 1

Amateur Communications Receiver 1

The Back Page 11

Anode Editor's Comments

Volume 12, Issue 4
October 2011

From GB2RS NEWS Sunday 2nd
October 2011

Another 'huge' bunch of Patches
"Patch Tuesday" this week. Make sure you download these "critical updates".

The End of the World - (Now happening on) October 21, 2011 (was May 2011)

Now would be a good time to :-

- ☐ Build that Direct Conversion Receiver.
- ☐ Attend to the mast fixing.
- ☐ Make sure that you have the VHF/UHF aerial for the next contest.

Take a look at:-

<http://cdmirror.textfiles.com>

For all those files and utility programs we used to use last century.

For several years the RSGB has been very actively involved in preparations for the 2012 World Radio Congress, or WRC-12. The work centres on creating a European Common Proposal, or ECP, for a secondary amateur allocation in the band 415 to 526.5 kHz. Society representatives have been working with one of CEPT's project teams to secure a positive outcome on this, the only amateur radio-related agenda item. At its meeting between 26 and 29 September the CEPT project team approved a draft ECP for an 8 kHz-wide band between 472 and 480 kHz. This draft ECP now goes to CEPT's Conference Preparatory

(continued on page 9)

Amateur Communications Receiver

by D. R. Bowman, A-11.1nst. E., G3LUB

Advanced design covering the 80, 40, 20, 15 and 10 metre bands. [This article is from Wireless World July 1969.]

1: Design considerations

For many years the author's amateur radio station has included a complex home-built dual conversion valve receiver. Throughout this time a number of solid-state receivers have been constructed, though it must be admitted that none has approached

the overall performance of the valve unit. The recent appearance of a number of new semiconductor devices coupled with the ever widening range of i.f. filters has prompted the author to re-appraise selected frequency band communication receiver design. A number of fundamental design requirements have been generally agreed for many years, but, in the final analysis, every receiver design is a compromise.

One of the biggest troubles is cross-modulation which can be experienced using almost all types of receiver. All

(Continued on page 2)

Special points of interest:

- Contact details on back page
- Ham - Comp Latest on web site.

Amateur Communications Receiver

(continued from page 1)

one needs to do is to tune to say 7 MHz at night, listen, and then insert a 20 dB attenuator in series with the receiving aerial. The effect is most enlightening as low-power signals re-appear from under the high power broadcast stations.

tunable i.f. also has the advantage of allowing the same basic tuning rate and dial calibration to be used on all received frequencies. The stability problems of tunable oscillators is also reduced as only one v.f.o. is required and it operates on a relatively low frequency, usually about 5 MHz. The first oscillator is invariably crystal controlled.

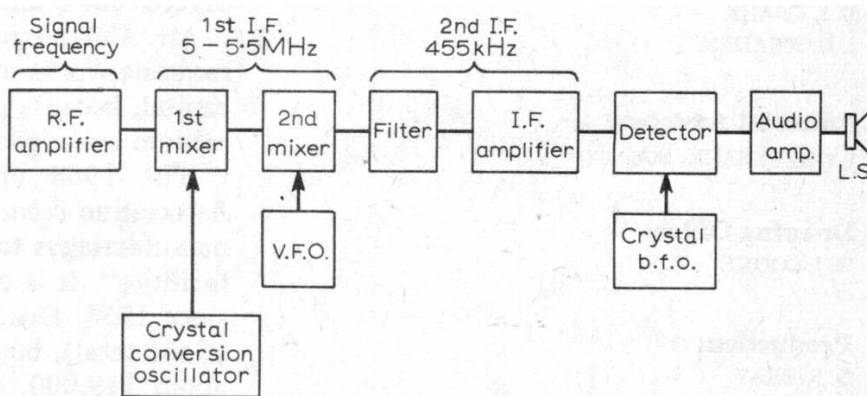

Fig. 1. The block diagram of a typical dual conversion receiver.

To reduce cross-modulation to the lowest level possible the selectivity must be as near to the front of the receiver as possible so as to reject the unwanted powerful signals before they can be amplified and cross-modulated in the mixer and to a lesser extent in the r.f. stages. Until recently first-rate i.f. selectivity has been unattainable above about 1 MHz and commercial filters were almost exclusively limited to frequencies in the region of 400 to 500 kHz. This limitation has forced designers either to accept poor image rejection or poor noise figures. Image rejection is a function of the r.f. circuit Q and the number of r.f. coils.

It will be shown that obtaining very high front-end selectivity and a good noise figure are conflicting requirements. It was this problem that led designers to introduce the dual conversion concept (Fig. 1). This system consists basically of a single conversion tunable receiver using a frequency band chosen to produce good image rejection, which in turn is fed from a range of h.f. converters each translating the required receiver band to the frequency of the tunable receiver. This use of a

There are some problems in this type of system. The already mentioned need for selectivity at the front-end is not met, but by restricting the pre-i.f. gain to the minimum consistent with good noise performance and the use of low noise mixer circuits, this problem can be minimized. A good a.g.c. (automatic gain control) system controlling the r.f. gain is also essential. The other main

problem, namely internally generated spurious frequencies, can be more or less overcome by the careful choice of conversion frequencies coupled with good physical screening. This said, it must be admitted that the dual conversion system is rather complex.

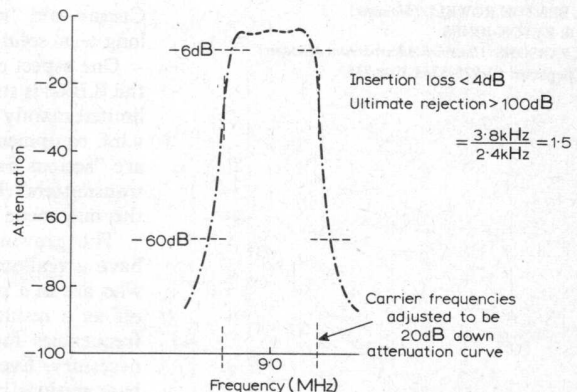

Fig. 2. Attenuation curve for the 9 MHz KVG XF-9B i.f. filter.

Recently a number of high-frequency crystal filters have become available. Although they are expensive, when it is realized that the

(Continued on page 3)

Amateur Communications Receiver

(Continued from page 2)

KVG XF9B 9 MHz filter (specified in the design) consists of a double lattice using eight crystals in addition to the two carrier crystals, the author considers that it is very good value for money. The ability to achieve good selectivity (see Fig. 2) at a high intermediate frequency lends itself to the use of a single conversion system (Fig. 3). The extremely narrow bandwidth of the 9 MHz filter led to the decision to design essentially for the single sideband reception for which the filter was intended. The performance of the completed receiver on e.w. is also very good and a.m. transmissions can be resolved using the exalted carrier method, i.e. the reception of only one sideband by zero beating the a.m. signal's carrier.

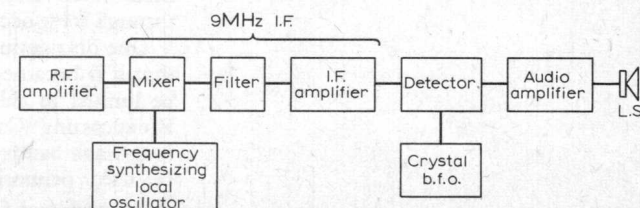

Fig. 3. The block diagram of a single conversion receiver.

The choice of a high i.f. means that the image response to the required signal ratio is very high; remembering that the image is displaced by twice the i.f. in frequency from the required signal; in this case 18 MHz.

Although a number of first quality receivers have been designed using no r.f. amplifier preceding the mixer the author decided to include an a.g.c. controlled amplifier, The 40-dB attenuation of signals that can be achieved ahead of the mixer does reduce the quantity of blocking and cross-modulation produced in the mixer stage of the receiver. The use of an r.f. amplifier also allows adequate pre-mixer selectivity to be used.

So far the proposed system appears too good to be true however there is a disadvantage. To tune the high-frequency amateur bands, say

10 metres, the local oscillator would have to tune either:

$$(28 \text{ to } 28.5) + 9 \text{ MHz} = 37 \text{ to } 37.5 \text{ MHz}$$

$$\text{or } (28 \text{ to } 28.5) - 9 \text{ MHz} = 19 \text{ to } 19.5 \text{ MHz.}$$

Either band is rather high in frequency for good stability using a free running oscillator and especially when it is realised that various switched ranges are required. It would be impossible to adjust the various tuning ranges so that the dual conversion systems advantage of a constant tuning rate and dial calibration on all ranges is achieved.

Various ideas were considered, the most promising being the heterodyne v.f.o. dating back to soon after the last war. It consists of a single range low-frequency v.f.o. fed to a mixer together with the output of an h.f. crystal oscillator; the output of the mixer circuit being tuned to the appropriate product (Figs. 4 and 5). This system was originally introduced as a means of avoiding the use of frequency multiplication with its associated output of unwanted frequencies. For receiver local oscillator use it is essential that the various frequencies are chosen carefully and that the unwanted components present in the output of the mixer circuit are not passed on to the main receiver mixer.

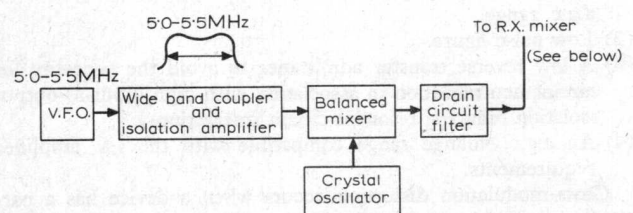

Synthesizer output		Crystal output	
Range:-		Range:-	
1	5.0-5.5MHz	1	None
2	16.0-16.5MHz	2	11MHz
3	5.0-5.5MHz	3	None
4	30.0-30.5MHz	4	25MHz
5	37.0-37.5MHz	5	32MHz
6	37.5-38.0MHz	6	32.5MHz
7	38.0-38.5MHz	7	33MHz

Fig. 4. The local oscillator synthesizer.

To avoid spurious signals within the bands the best v.f.o. frequency range is found to be 7.6

(Continued on page 4)

Amateur Communications Receiver

(Continued from page 3)

to 8.1 MHz, but this does mean that each amateur band covered requires a separate crystal (table I), If an odd one or two spurious whistles can be tolerated then, with a v.f.o. range of 5 to 5.5 MHz, two of the bands can be covered using no h.f. crystal oscillator.

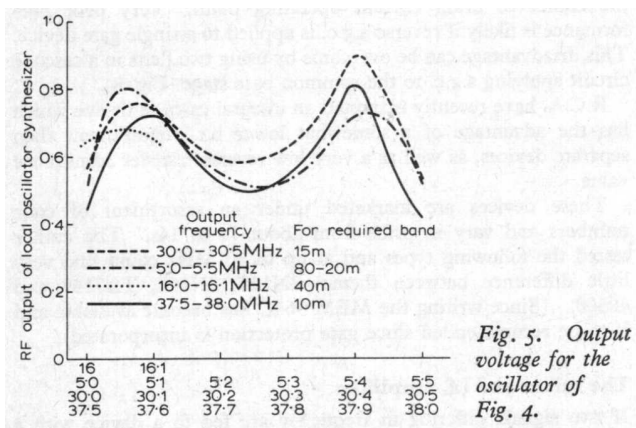

Fig. 5. Output voltage for the oscillator of Fig. 4.

Required band **v.f.o.** **i.f.**
 (3.5 to 4 MHz) + (5 to 5.5 MHz) ~ 9 MHz
 (14 to 14.5 MHz) - (5 to 5.5 MHz) ~ 9 MHz

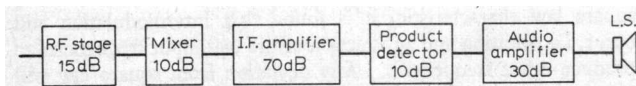

Fig. 6. Gain distribution throughout the receiver.

One more slight disadvantage is that the receiver tuning direction will be reversed on one of the ranges. However, on 20 and 80 metres the receiver's performance is likely to surpass even the most advanced commercial unit.

It will be noted that one harmonic of the v.f.o. falls within the 15-metre band. The amplitude of this spurious signal can be reduced to a very low level by careful v.f.o. circuit design in conjunction with extra filtering and good mixer design. This method of local oscillator frequency generation does lend itself to a constant tuning rate and dial calibration on all ranges.

The next basic decision that a receiver designer has to make is the gain distribution throughout the receiver (Fig. 6). At first sight it would seem that the best receiver would embrace the maximum signal gain.

The random motion of free electrons in wires and resistors generates small currents, even though the average over a finite time of these currents is zero. At any one time this contributes a small noise current to the circuit. From these small currents are derived voltages which are named "white noise" because they spread more or less evenly throughout the frequency spectrum.

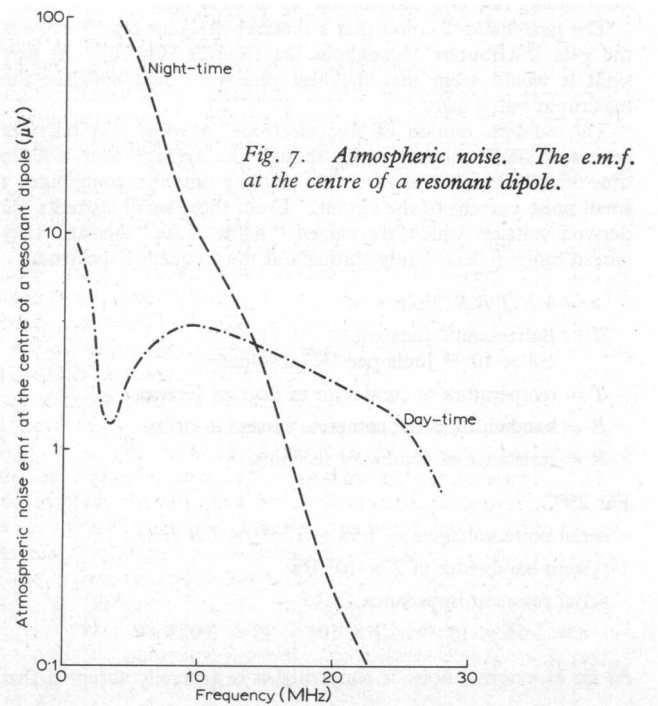

Fig. 7. Atmospheric noise. The e.m.f. at the centre of a resonant dipole.

$$e = 4 \cdot K \cdot T \cdot B \cdot R \text{ Volts}$$

K = Boltzmann's constant
 1.3×10^{-23} joule per Kelvin (absolute)
 T = temperature of conductor in degrees Kelvin
 B = bandwidth of the complete system in Hertz.
 R = resistance of conductor in ohms.

For 25C:
 aerial noise voltage $e = 1.55 \times 10^{-20} \cdot BR$ volts
 system bandwidth of 2×10^3 Hz

(continued on page 5)

Amateur Communications Receiver

(Continued from page 4)

aerial resonant impedance 75 Ohms :

$$e = 1.55 * 10^{-20} * 2 * 10^3 * 75 = 0.023 \text{ uVolts}$$

As far as external noise is concerned it is generally accepted that over the frequency range 1 to 14 MHz the minimum external noise level will be at least 30 dB above the ideal figure quoted above (Fig. 7). Even from 14 to 30 MHz the level can be expected to be only about 10 dB better. This external noise is made up from various sources. Electrical storms in widely separated parts of the world contribute noise in addition to cosmic sources originating from the milky way. It is generally accepted that a signal must exceed the noise level by at least 10 dB to be readable.

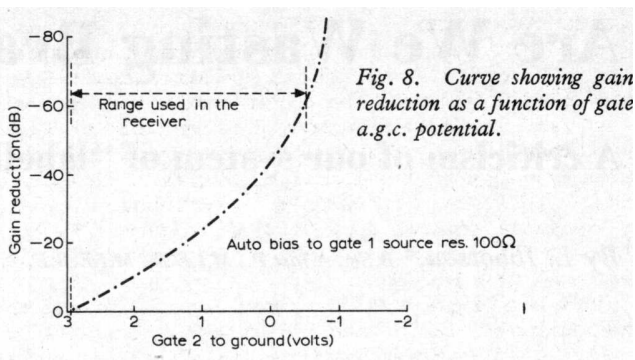

Fig. 8. Curve showing gain reduction as a function of gate a.g.c. potential.

This sets the minimum noise level at 30 dB above 0.023 uV or 0.7 uV, over the range 1 to 14 MHz, and 20 dB above 0.023 uV, or 0.23 uV above 14 MHz.

For a 10 dB signal ratio the minimum detectable signal levels will therefore be 2.1 uV from 1 to 14 MHz and 0.21 uV above 14 MHz.

Although these noise figures vary considerably from area to area they can be taken as a starting point.

In a well designed unit the vast majority of the receiver noise originates from the first r.f. stage; the succeeding mixer contributing only about 1 dB. To reduce cross-modulation to a

low level it is essential to reduce the amplitude of strong off-channel signals before they reach the mixer. To do this it would seem that a number of high-Q tuned circuits ahead of the r. f. stage could be used. It can be shown that in fact excessive pre-r.f. stage selectivity considerably worsens the overall noise figure. In general it can be said that the lowest noise figure coincides with minimum signal loss between aerial and the first r.f. amplifier device. Maximum power transfer occurs when the signal source is matched to the load. As noise performance is most important on the higher frequency ranges, 10 metres has been taken as the starting point.

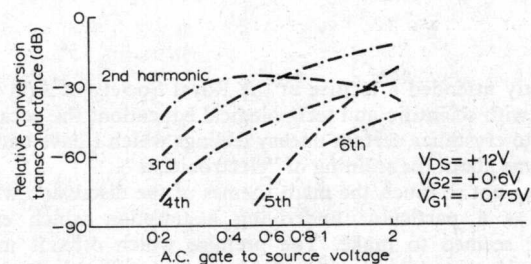

Fig. 9. Showing the relative conversion gain of several harmonics as a function of oscillator voltage (reproduced with the permission of R.C.A.).

Assuming stray capacitances to be of the order of 10 pF then the minimum value of C is taken as 15 pF which at 30 MHz resonates with a 2 Micro Henrys.

Assuming an unloaded Q of 100 then:

$$Q = (2 * \pi * F * L) / R$$

$$\text{therefore: } R = (2 * \pi * F * L) / Q$$

$$= (2 * \pi * 30 * 10^6 * 2 * 10^{-6}) / 100$$

$$= 3.8 \text{ Ohms}$$

the dynamic resistance of the parallel tuned circuit RD is:

$$RD = L / (CR)$$

$$= (2 * 10^{-6}) / (15 * 10^{-12} * 3.8)$$

$$= 35.1 \text{ kOhms}$$

If maximum power transfer from the aerial to the tuned circuit occurs then the value of R8 is transformed up to ZD and the effective resistance in parallel with the tuned circuit

(Continued on page 6)

Amateur Communications Receiver

(Continued from page 5)

becomes $R_D/2 = 17 \text{ k}\Omega$. The tuned circuit must of course also match the input impedance of the amplifying device. The device chosen has an input impedance that varies with frequency. At 3 MHz it is very high dropping to as low as 20 Ω at 30 MHz. It will be noted throughout this analysis that the reactive part of the devices input and output impedance is ignored. This can be justified as the reactive portion becomes part of a tuned circuit.

The total parallel resistance:

$$(17 \text{ k} * 20 \text{ k}) / (17 \text{ k} + 20 \text{ k}) = 9.2 \text{ k}$$

Therefore the circuit loaded Q is:

$$Q = R_p / (2 * P_i * F * L_p) \\ = (9.2 \times 10^3) / (2 * P_i * 30 * 10^6 * 2 * 10^{-6}) \\ = 24$$

Therefore it is shown that minimum noise figure does not occur with maximum selectivity in the r.f. stage. A compromise has to be made between noise figure and selectivity. This does not mean that overall system selectivity has to suffer as this is determined by the i.f. filter. The best compromise is to trade excess r.f. gain for increased selectivity by reducing the loading on the r.f. to mixer coupling circuit. This has the extra advantage of increasing the r.f. amplifier's stability factor. Care must be taken not to reduce the gain too much. The author decided to aim for a noise figure of 12 dB on the I.f. bands and better than 8 dB on 10 metres.

R.F. amplifier

The requirements for the r.f. amplifier were as follows:

- (1) Very good immunity to cross-modulation and blocking over the a.g.c. range.
- (2) Low noise figure.
- (3) A low reverse transfer admittance to avoid the necessity for circuit neutralization in association with high input-to output isolation reducing resonant circuit interaction.

- (4) An a.g.c. voltage range compatible with the i.f. amplifier requirements.

Cross-modulation distortion occurs when a device has a particular transfer characteristic and is fed with two differing frequency signals. As long as the transfer characteristic is linear or follows a square law then the gain applied to signal two is independent of the second signal's amplitude. If the transfer characteristic deviates from a linear or a square law the gain on signal one will be modulated by the amplitude of signal two.

An investigation into various semiconductor devices shows that only the field effect transistor has a transfer characteristic of approximately square law. Bipolar devices are particularly poor in this respect. During some earlier work the author found that even f.e.t. cross-modulation performance is determined in part by the choice of drain current operating point. Very poor performance is likely if reverse a.g.c. is applied to a single gate device. This disadvantage can be overcome by using two f.e.t.'s in a cascode circuit applying a.g.c. to the common base stage (Fig. 8).

R.C.A. have recently marketed an integral cascode device which has the advantage of a somewhat lower h.t. requirement than separate devices, as well as a very low reverse transfer admittance value.

These devices are marketed under an assortment of code numbers and vary in price from about 7s to 14s. The author tested the following types and at up to 30 MHz could find very little difference between them:-

3N140, 3N141, TA7149 and 40500. (Since writing the MEM 564C has become available and is to be recommended since gate protection is incorporated).

The mixer and i.f. Amplifier

If two signals differing in frequency are fed to a

(continued on page 7)

Amateur Communications Receiver

(Continued from page 6)

device with a square law characteristic, it is found that intermodulation will occur, i.e. addition and subtraction of the two input frequencies to produce other frequencies. Any deviation from square law will introduce cross-modulation and therefore the dual gate f.e.t. is as equally applicable to mixers as amplifiers. It has the added advantage that the two signals can be fed to separate gate electrodes to provide considerable isolation between the local oscillator and the signal voltages. The characteristics of this mixer are such that the overload performance is improved with a limited reduction in oscillator drive voltage. The mixer gain is of course also reduced and spurious signal generation suffers a very much greater reduction. The optimum value of oscillator injection for the authors' application was 0.3 V, lower voltages than this impaired the noise performance and, above 0.5 V, the unwanted harmonic generation becomes excessive (Fig. 9).

One of the many advantages of using the 3N140, which is really intended for v.h.f. use, is the constant value of the output impedance over a range of 1 to 30 MHz. The i.f. amplifier was designed with the following factors in mind:

- (1) Maximum gain of 70 dB centred on 9 MHz.
- (2) At least 80 dB of automatic gain control.
- (3) Wide bandwidth, say 300 kHz, as one method of avoiding frequency shift with a.g.c. action. Note the selectivity is determined by an 8-pole, 9 MHz, crystal filter.
- (4) A.G.C. voltage sense and range compatible with the amplifier. Many circuit configurations were considered for use in the i.f. amplifier.

The use of common emitter transformer coupled stages was avoided due to the high value of reverse admittance, making either

circuit neutralization or low gain per-stage essential to ensure an adequate stability factor. The cascode arrangement of bipolar devices was investigated. It was decided that there was little advantage in using field effect transistors in the i.f. amplifier as the cross-modulation problem is minimal after the very narrow bandwidth filter. The cascode arrangement was found to exhibit high-gain with a very low reverse admittance. The circuit also lends itself to a.g.c. control rather in the same manner as the r.f. amplifier. The control voltage is applied to the common base connected stage. This in turn means that the r.f. and i.f. controlled sections can easily be coupled together. It was found that the cascode arrangement induced very much less de-tuning of the i.f. transformers and by using low Q single tuned circuits very little change in the overall i.f. response occurs with a.g.c. Action.

Although two high-gain sections could be designed to provide the required gain, the author's previous experience suggested that to be sure of maintaining stability three stages incorporating a total of six transistors -be used. The gain required is spread between the three stages. The possibility of using a capacitive potential divider across the i.f. coils to provide the consecutive base drive was investigated. It was found that the very long earth paths made a stable reproduceable design very difficult. The amplifier was very much easier to handle using low impedance coupling coils on the i.f. transformers.

During tests of the i.f. amplifier the a.g.c. gave the following performance: With a change of input signal of -50 dB below 200 mV the output dropped by -3 dB; and a change of input signal of -80 dB produced a drop of -10 dB at the output. The amplifier had a gain of 90 dB, and showed tendencies towards instability only when this figure was exceeded.

The stage from which the a.g.c. is derived is a

(Continued on page 8)

Amateur Communications Receiver

(Continued from page 7)

single transistor biased so that, with no signal, it is very nearly switched off. As the signal increases so the average collector current also increases and the collector voltage change is approximately proportional to the output of the i.f. Amplifier.

For the reception of a single sideband transmission the normal fast attack, fast recovery, a.g.c. characteristic is useless. Because the transmission has no steady carrier wave the fast a.g.c. system tries to follow each syllable. One method of using a.g.c. with s.s.b. is to tailor the response to fast attack, slow delay. This has the effect of reducing the receiver's gain almost instantaneously, but delaying the release for the order of a second or so.

The detector frequency oscillator

The product detector can be considered as a mixer in which the input i.f. signal is mixed with a beat frequency oscillator to produce an output whose frequency spectrum falls in the audio range. This system of detection is used to demodulate amplitude modulated signals which are treated as if they were single sideband transmissions. In a noiseless system there is a 3 dB signal loss relative to s.s.b. but under crowded amateur band conditions it is found that the ability to select either sideband reduces the chance of a heterodyne blotting out the a.m. Signal.

Remembering that the i.f. bandwidth is only 2.4 kHz wide, it was decided not to incorporate a conventional a.m. detector due to the rather restricted audio response of 0 to 1.2 kHz that would result.

A number of product detector circuits were investigated including one using an f.e.t. The author decided that the extra expense of an f.e.t. detector was not warranted. The circuit used is a balanced bipolar arrangement which requires a very low b.f.o. injection voltage of

about 100 mV. This small oscillator voltage requirement helps the constructor to avoid stray b.f.o. signals getting into early stages of the i.f. amplifier. The use of a high i.f. amplifier does tend to increase this risk. The detector will operate at low distortion, with an i.f. signal no greater than 10 mV, and exhibits a gain of the order of 10 dB.

At an early stage in the design it was decided to use a crystal controlled b.f.o., whereas, when using an IS. system the crystal frequencies have to be specified accurately, it was found that at 9 MHz the frequencies can be easily adjusted over a few kHz. This final adjustment is carried out by connecting a small trim capacitance in parallel or series with the individual crystals. If the frequency is too high then parallel C is required and if too low, series C is required. The final frequencies being set 20 dB down either side of the filter characteristic. It will be noted later that the crystal is election uses germanium diodes which allow the control switch to be positioned remote from the actual circuit.

This completes the description of the basic system and the points that have either been dealt with fleetingly or not at all will be covered in the practical description which starts next month. The receiver will show up well in comparison even with very expensive commercial units, but, it is complex and only constructors with considerable previous experience are advised to tackle its construction. The use of a valve voltmeter together with a signal generator would be very helpful, but not essential.

(to be continued - yes I do have the August 1969 issue.)

Taken from:
Wireless World, July 1969 pages 299-301

Editor's Comments & News

(Continued from page 1)

Group for formal ratification in November. This breakthrough, at the 11th and final meeting of the project team, occurred with the submission by Ofcom of an RSGB-drafted compromise ECP proposal. Whilst the 8 kHz band differs from that agreed by CITELE, a similar regional grouping of countries to CEPT but in the Americas, there is a 6 kHz overlap. Of course there is still some way to go, but the prospect of an agreed CEPT position is good progress, representing a 48 country block vote going into next year's WRC-12. It needs to be noted that the draft ECP comes with significant caveats to avoid interference to the primary user, as well as the existing secondary user services. These are the maritime and aeronautical radio navigation services respectively. As secondary users we would also not be afforded any protection. It should be acknowledged that we have had support from a number of Region 1 national societies as well as Ofcom in getting to this position

The British Astronomical Association is organising a meteor watch exercise for the coming Draconids shower, between 7 and 9 October. It would be interesting to compare meteor scatter counts against activity reported by visual observers up and down the country. The Draconids are not normally a large event but are subject to occasional outbursts and there has been speculation that this year could produce one of these. Observations are requested across the three days of 7, 8 and 9 October. Preferably these would be around-the clock, but if this is not possible, between 1500 and 2300UTC on the three days. Counts in 15-minute bins will be appropriate for most of the time but on the evening of 8 October, most likely between 1800 and 2100UTC, the rates may be changing very quickly and so it would be advantageous to have the counts in 5-minute bins. It is very important that receiver settings and antenna alignment are kept constant throughout the period of observation. If possible, the beam of the antenna should be directed towards the mid-point of the great circle path joining the transmitter and receiver locations.

Paul Hyde, G4CSD the BAA Coordinator for the Radio Astronomy Group, will be consolidating the observations into a single report which will be sent to all participants. Please contact him by e-mail to radiogroup@britastro.org for further information on how to submit reports.

The T32C DXpedition to Kirimitati now has 10 Yaesu FT-450 transceivers and eight linear amplifiers on the island, along with the hardware to put up gain antennas for 10 through 80 metres, and a big vertical for 160m. They also plan to install Beverages for receiving. Operation should be in full swing by this weekend and they aim to post any breaking news on the DXpedition website, www.t32c.com.

JOTA

The 54th Jamboree On The Air will take place on 15 and 16 October. This year's theme is Peace, Environment and Natural Disasters. Within this year's JOTA, an emergency communications exercise will take place on Saturday, 15 October, 2011 in the afternoon, European time zone. This simulated emergency test will include the Headquarters station, HB9S, of the World Organisation of the Scout Movement, which will be operated by amateurs from 5 different countries.

The West Rand Amateur Radio Club
 Established in 1938
 KG33XU 26.14122 South - 27.91870 East

P.O. Box 5344
 Weltevreden Park
 1715

Phone: 083 267 3835 (Chairman)
 Email: zs6wr.club@gmail.com
 Web page: www.zs6wr.co.za

Bulletins (Sundays at ...)
 11h15 Start of call in of stations
 11h30 Main bulletin start

Frequencies
 Output: 439.000 MHz 7.6 MHz split
 Input: 431.4 MHz (West Rand Repeater)
 145,625 MHz (West Rand Repeater)
 (HF Relay when possible)

Radio Amateurs do it with more frequency!

Chairman (technical)	Phillip van Tonder	ZS6PVT	083 267 3835	zs6wr.club@gmail.com OR zs6pvt@gmail.com
Vice Chairman	Geoff Levey	ZS6GRL	082 546 5546	glevey@gmail.com
Secretary	Rory Crouch	ZS6RBJ	082 448 4445	rorycrouch@mweb.co.za
Treasurer	David Cloete	ZR6AOC	083 449 8991	zr6aoc@mweb.co.za
Member	Romeo Nardini	ZS6ARQ	082 552 4440	roshelec@global.co.za
Member (Anode & Technical)	John Brock	ZS6WL	011 768 1626	brockjk@gmail.com
Member	Johan van Vuuren	ZS6JVV	082 558 5811	johanvv@absamail.co.za
SARL Liaison	Willem Weideman	ZS6WWJ	082 890 6775	willem@zs6wwj.co.za

West Rand members - we need your input!

To make this the best ham radio magazine in South Africa we need your input. Please submit articles, comments, suggestions etc.

Please send plain text with no formatting to the email address below.

See Club website at www.zs6wr.co.za for all ANODE back issues.

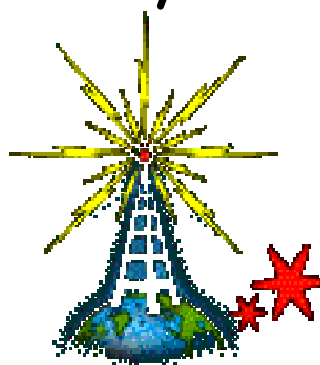

We need your input! Email us articles, comments and suggestions please.
zs6wr.club@gmail.com